



ドリル径
ø0.6~13.0 mm

IT8-10
精度目安



15°
ねじれ角

3
L/D

135°
先端角

難削材（高硬度材）用穴加工
ノンコーティングソリッドドリル

外部給油



ドリル径 øDc	øDc ≤ 3.0	3.0 < øDc ≤ 6.0	6.0 < øDc ≤ 10.0	10.0 < øDc ≤ 13.0
許容差	0 -0.010	0 -0.012	0 -0.015	0 -0.018

外径バックテーパ 0.04 ~ 0.07/100

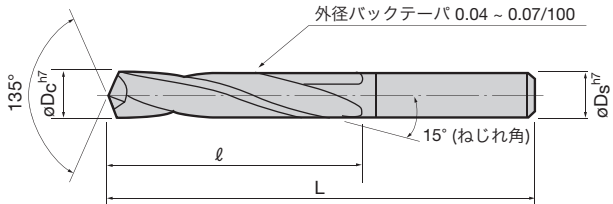

øDc = øDs

L/D = 3

ドリル径 øDc	形番	在庫	寸法 (mm)	
			ℓ	L
0.6	DMD-006S	◇	5	40
0.7	DMD-007S	◇		
0.8	DMD-008S	◇		
0.9	DMD-009S	◇	6	
1.0	DMD-010S	◇		
1.1	DMD-011S	◇		
1.2	DMD-012S	◇	8	
1.3	DMD-013S	◇		
1.4	DMD-014S	◇	9	
1.5	DMD-015S	◇		
1.6	DMD-016S	◇	10	
1.7	DMD-017S	◇		
1.8	DMD-018S	◇	11	
1.9	DMD-019S	◇		
2.0	DMD-020S	◇	12	
2.1	DMD-021S	◇		
2.2	DMD-022S	◇	13	
2.3	DMD-023S	◇		
2.4	DMD-024S	◇	14	
2.5	DMD-025S	◇		
2.6	DMD-026S	◇	16	
2.7	DMD-027S	◇		
2.8	DMD-028S	◇	18	
2.9	DMD-029S	◇		
3.0	DMD-030S	◇	20	
3.1	DMD-031S	◇		
3.2	DMD-032S	◇	22	
3.3	DMD-033S	◇		
3.4	DMD-034S	◇	25	
3.5	DMD-035S	◇		
3.6	DMD-036S	◇	27	
3.7	DMD-037S	◇		
3.8	DMD-038S	◇	28	
3.9	DMD-039S	◇		
4.0	DMD-040S	◇		
4.1	DMD-041S	◇		
4.2	DMD-042S	◇		
4.3	DMD-043S	◇		
4.4	DMD-044S	◇		
4.5	DMD-045S	◇		
4.6	DMD-046S	◇		
4.7	DMD-047S	◇		
4.8	DMD-048S	◇		
4.9	DMD-049S	◇		
5.0	DMD-050S	◇		
5.1	DMD-051S	◇		

ドリル径 øDc	形番	在庫	寸法 (mm)	
			ℓ	L
5.2	DMD-052S	◇	28	65
5.3	DMD-053S	◇		
5.4	DMD-054S	◇	30	
5.5	DMD-055S	◇		
5.6	DMD-056S	◇	32	
5.7	DMD-057S	◇		
5.8	DMD-058S	◇	35	
5.9	DMD-059S	◇		
6.0	DMD-060S	◇	38	
6.1	DMD-061S	◇		
6.2	DMD-062S	◇	40	
6.3	DMD-063S	◇		
6.4	DMD-064S	◇	45	
6.5	DMD-065S	◇		
6.6	DMD-066S	◇	50	
6.7	DMD-067S	◇		
6.8	DMD-068S	◇	55	
6.9	DMD-069S	◇		
7.0	DMD-070S	◇	60	
7.1	DMD-071S	◇		
7.2	DMD-072S	◇	65	
7.3	DMD-073S	◇		
7.4	DMD-074S	◇	70	
7.5	DMD-075S	◇		
7.6	DMD-076S	◇	75	
7.7	DMD-077S	◇		
7.8	DMD-078S	◇	80	
7.9	DMD-079S	◇		
8.0	DMD-080S	◇	85	
8.1	DMD-081S	◇		
8.2	DMD-082S	◇	90	
8.3	DMD-083S	◇		
8.4	DMD-084S	◇	95	
8.5	DMD-085S	◇		
8.6	DMD-086S	◇	100	
8.7	DMD-087S	◇		
8.8	DMD-088S	◇	105	
8.9	DMD-089S	◇		
9.0	DMD-090S	◇	110	
9.1	DMD-091S	◇		
9.2	DMD-092S	◇	115	
9.3	DMD-093S	◇		
9.4	DMD-094S	◇	120	
9.5	DMD-095S	◇		
9.6	DMD-096S	◇	125	
9.7	DMD-097S	◇		

ドリル径 øDc	形番	在庫	寸法 (mm)	
			ℓ	L
9.8	DMD-098S	◇	55	90
9.9	DMD-099S	◇		
10.0	DMD-100S	◇		
10.1	DMD-101S	◇		
10.2	DMD-102S	◇		
10.3	DMD-103S	◇		
10.4	DMD-104S	◇		
10.5	DMD-105S	◇		
10.6	DMD-106S	◇		
10.7	DMD-107S	◇		
10.8	DMD-108S	◇		
10.9	DMD-109S	◇		
11.0	DMD-110S	◇		
11.1	DMD-111S	◇		
11.2	DMD-112S	◇		
11.3	DMD-113S	◇		
11.4	DMD-114S	◇		
11.5	DMD-115S	◇		
11.6	DMD-116S	◇		
11.7	DMD-117S	◇		
11.8	DMD-118S	◇		
11.9	DMD-119S	◇		
12.0	DMD-120S	◇		
12.1	DMD-121S	◇		
12.2	DMD-122S	◇		
12.3	DMD-123S	◇		
12.4	DMD-124S	◇		
12.5	DMD-125S	◇		
12.6	DMD-126S	◇		
12.7	DMD-127S	◇		
12.8	DMD-128S	◇		
12.9	DMD-129S	◇		
13.0	DMD-130S	◇	90	130

(注) 使用上の注意・再研削上の注意・推奨切削条件は、DMD-Tと同様ですので、ご参照ください。

製品在庫 ◇:当商品は専門店在庫です

11

難削材・高硬度材用 DMD